

MV 2 SERIES

GENERAL PURPOSE

OPEN TOP RANGES

OWNER'S MANUAL

Country of Destination
GB and IE

IMPORTANT CUSTOMER INFORMATION

Please check the gas tap and thermostat will press and release freely prior to lighting the burner, as this is part of the unit's safety mechanism.

It is particularly important to check this following spillage as solidified fats and carbonised meat juices can impair the valves correct operation.

IMPORTANT INFORMATION INSTALLATION ENGINEER

Please ensure the customer is made fully aware of how the gas tap and thermostat operate and the importance of checking its operation daily.

Model No.	Product Description	Rev.	Date	Flexible Hose Size
	Mv2 Gas Ranges			
MV2RGP60-OT-NG	600 Open Top 4 Burner Range NG	1	01-02-08	¾" BSP hose
MV2RGP60-OT-NG-C	600 Open Top 4 Burner Range NG With Castors	1	01-02-08	¾" BSP hose
MV2RGP60-OT-NGV	600 Open Top 4 Burner Range NG with VE Pan Supports	1	01-02-08	¾" BSP hose ¾" BSP hose
MV2RGP90-OT-NG	900 Open Top 6 Burner Range NG	1	01-02-08	1" BSP hose
MV2RGP90-OT-NG-C	900 Open Top 6 Burner Range NG With Castors	1	01-02-08	1" BSP hose
MV2RGP90-OT-NGV	900 Open Top 6 Burner Range NG with VE Pan Supports	1	01-02-08	1" BSP hose
MV2RGP120-OT-NG	1200 Open Top 8 Burner Range NG	1	01-02-08	¾" BSP hose
MV2RGP120-OT-NG-C	1200 Open Top 8 Burner Range NG With Castors	1	01-02-08	¾" BSP hose
MVRGP120-OT-NGV	1200 Open Top 8 Burner Range NG with VE Pan Supports	1	01-02-08	¾" BSP hose
MV2RGP60-OT-LP	600 Open Top 4 Burner Range LP	1	01-02-08	¾" BSP hose
MV2RGP60-OT-LP-C	600 Open Top 4 Burner Range LP With Castors	1	01-02-08	¾" BSP hose
MV2RGP60-OT-LPV	600 Open Top 4 Burner Range LP with VE Pan Supports	1	01-02-08	¾" BSP hose
MV2RGP90-OT-LP	900 Open Top 6 Burner Range LP	1	01-02-08	¾" BSP hose
MV2RGP90-OT-LP-C	900 Open Top 6 Burner Range LP With Castors	1	01-02-08	¾" BSP hose
MV2RGP90-OT-LPV	900 Open Top 6 Burner Range LP with VE Pan Supports	1	01-02-08	¾" BSP hose
MV2RGP120-OT-LP	1200 Open Top 8 Burner Range LP	1	01-02-08	¾" BSP hose
MV2RGP120-OT-LP-C	1200 Open Top 8 Burner Range LP With Castors	1	01-02-08	¾" BSP hose
MV2RGP120-OT-LPV	1200 Open Top 8 Burner Range LP With VE Pan Supports	1	01-02-08	¾" BSP hose

INDEX

	Page
Cover Sheet:	1
Important Information Sheet	2
Revision Sheet:	3
Index:	4
Introduction:	5 & 6
General Introduction	5
Important Note	6
Specification:	7 – 11
Gas Pressure / Connection	7 & 8
Overall Dimensions	9 – 11
Installation:	12 – 14
Important Note1	12
Positioning	12 & 13
Checking & Commissioning	14
User's Instruction:	15 – 22
Important Note	15
Operation	16 – 18
Cooking Guide	19
Cleaning	19 – 22
Service & Maintenance:	23 – 28
Routine Maintenance	23
Fault Finding	24
Instructions	25 – 28
Spare Parts:	29 & 30
Warranty Cover Sheet:	31
Check List:	32

INTRODUCTION

This manual contains all the required information to ensure that your new appliance is installed and serviced correctly and that you have all the information necessary to identify and order spare parts. It also contains comprehensive instructions for the user and for cleaning the appliance.

To maintain peak performance, it is recommended that the appliance be regularly serviced and that when ordering spare parts, reference is made to the appropriate list quoting the Part Number and Description contained therein. **THE FITTING OF A NON STANDARD PART MAY VOID ANY GUARANTEE.**

All work carried out on this appliance during installation or servicing must be performed by a competent person and the connection of the appliance to the gas supply **MUST** be carried out by qualified personnel in accordance, where applicable, with the relevant regulations.

The siting of the appliance and the connection to the gas supply must comply with the latest **GAS SAFETY (INSTALLATION & USE) REGULATIONS 2000**; the requirements of the **FIRE PRECAUTIONS ACT 1971**; the **HEALTH & SAFETY AT WORK, ETC ACT 1974**, the **BUILDING STANDARDS (SCOTLAND) CONSOLIDATION REGULATIONS 1971**. Detailed recommendations are contained in British Standards **BS5440 Part 1:2000**, **BS5440: Part 2:2000**, **BS5588: Part 0:1996**, **BS5588: Part 11:1997 & BS6173: 2001**.

An easily accessible stopcock must be fitted in the gas supply adjacent to the appliance for use in an emergency.

The details of the gas supply will be found on the Data Plate, which is located on the rear of the flue upstand/splashback panel.

Improvements

The policy of **Viscount Catering Ltd** is such that, each product is subject to continual development and may, therefore, be subsequently improved. The company reserves the right to alter the design of any appliance without prior notification and without the responsibility to update any delivered or in-service appliance and furthermore, without incurring the responsibility for altering these instructions. In such circumstances, it may be found that the appliance detailed herein differs in certain respects from the one supplied.

IT IS IMPORTANT, THEREFORE, TO QUOTE THE SERIAL No. AND THE APPLIANCE MODEL No. IN ALL COMMUNICATIONS WITH THE COMPANY.

Introduction (cont.)

Important

Before installing any item please refer to the installation instructions.

We recommend that all servicing other than routine cleaning be carried out by our authorised service agents and will accept no responsibility for work carried out by other persons.

For satisfactory operation, parts of catering equipment become hot. Suitable precautions must be taken to avoid accidental burns therefore the appliance should be positioned to minimise the possibility of accidental touching. It is the supervisor's responsibility to warn users to wear suitable protection and to follow correct operation and cleaning procedures.

For the details of your nearest Service Agent for all warranty repair work, you should contact:-

The Service Department,
Enodis UK Food Service Group
Enodis House
5E Langley Business Centre
Station Road
Langley
Berkshire
SL3 8DS

Tel: +44 (0) 1753 485902

Fax: +44 (0) 845 301 1461

Spares can be obtained via the Spare Parts Department at the above address.

IT IS IMPORTANT, TO QUOTE THE SERIAL No. AND THE APPLIANCE MODEL No. IN ALL COMMUNICATIONS WITH THE COMPANY.

SPECIFICATION

900 Open Top Range
 600 Open Top Range
 1200 Open Top Range

6 Open Top Burners with Oven
 4 Open Top Burners with Oven
 8 Open Top Burners with Two Ovens

Gas Pressure

	Supply Pressure	Adjusted Pressure
Natural Gas	20 mbar (8" wg)	15 mbar (6" wg)
Propane Gas	37 mbar (14.8" wg)	37 mbar (14" wg)

Gas Connection

¾" BSP Taper Male (Rp 3/4")

Heat Input (Nett Values)

INDIVIDUAL BURNERS ONLY	INJECTOR		NATURAL GAS			PROPANE		
	NG	LP	m ³ /h	Btu/h	kW	Kg/h	Btu/h	kW
900 Oven	2.44mm	1.32mm	0.775	24,975	7.32	0.448	19,516	5.72
600 Oven	1.99mm	1.18mm	0.519	16,718	4.90	0.365	15,899	4.66
Open Top	2.0mm	1.2mm	0.64	20,472	6.00	0.432	18,424	5.4
TOTALS								
900 Open Top Range			4.615	147,807	43.32	3.1	130,060	38.12
600 Open Top Range			3.079	98,606	28.9	2.133	89,595	26.26
1200 Open Top Range			6.414	205,469	60.22	4.34	182,807	53.58
900 Open Top Range low rate					1.0			1.02
600 Open Top Range low rate					0.73			1.02
1200 Open Top Range low rate					1.1			1.2

Specification (cont.)

Burner Injectors

	Natural gas	Propane Gas
900 Oven	2.44mm (41M)	1.32mm (55M)
900 Oven By-pass	ADJUSTABLE	0.55mm
600 Oven	1.99mm (47M)	1.18mm (56M)
600 Oven By-pass	ADJUSTABLE	0.55mm
Open Top Burner	2.0mm (51M)	1.2mm (59M)
Open Top Burner Low Rate	Adjustable	0.60mm

Oven Dimensions

	900 Oven	600 Oven
Oven Cavity – Width	720mm	425mm
Oven Cavity – Depth	608mm	608mm
Oven Cavity – Height	480mm	480mm
Nominal Volume	0.2m ³ (7.4 ft ³)	0.123m ³ (4.3 ft ³)
Shelf sizes	685mm x 500mm	385mm x 500mm
Volume of Cooking Space	0.17m ³ (5.9 ft ³)	0.09m ³ (3.3 ft ³)

Weight

900 Open Top Range	135kg
600 Open Top Range	105kg
1200 Open Top Range	190kg

Specification (cont.)

600mm Open Top Range

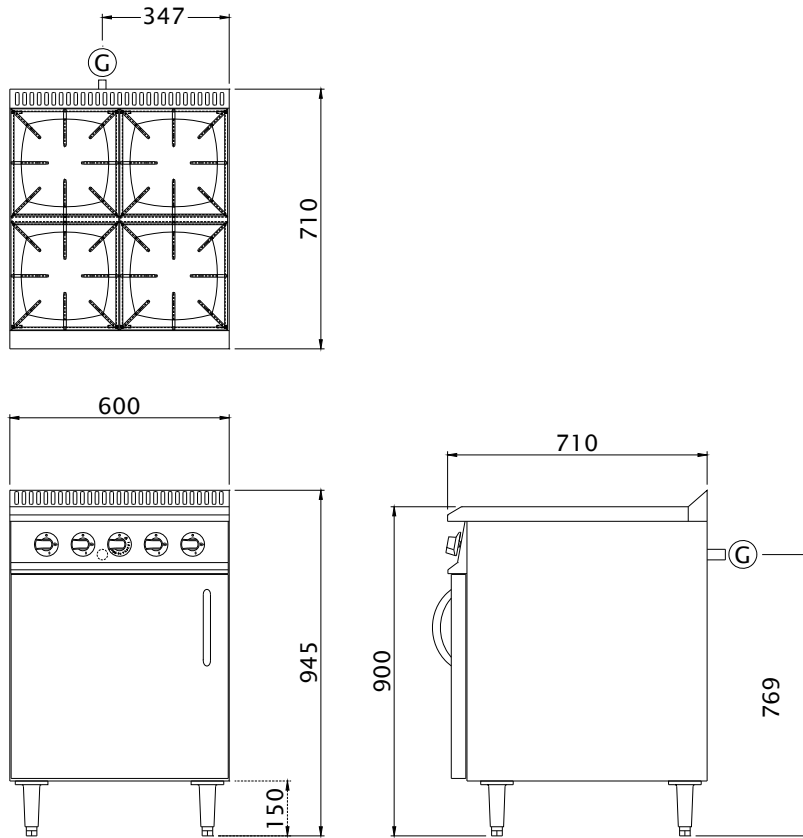

Specification (cont.)

900mm Open Top Range

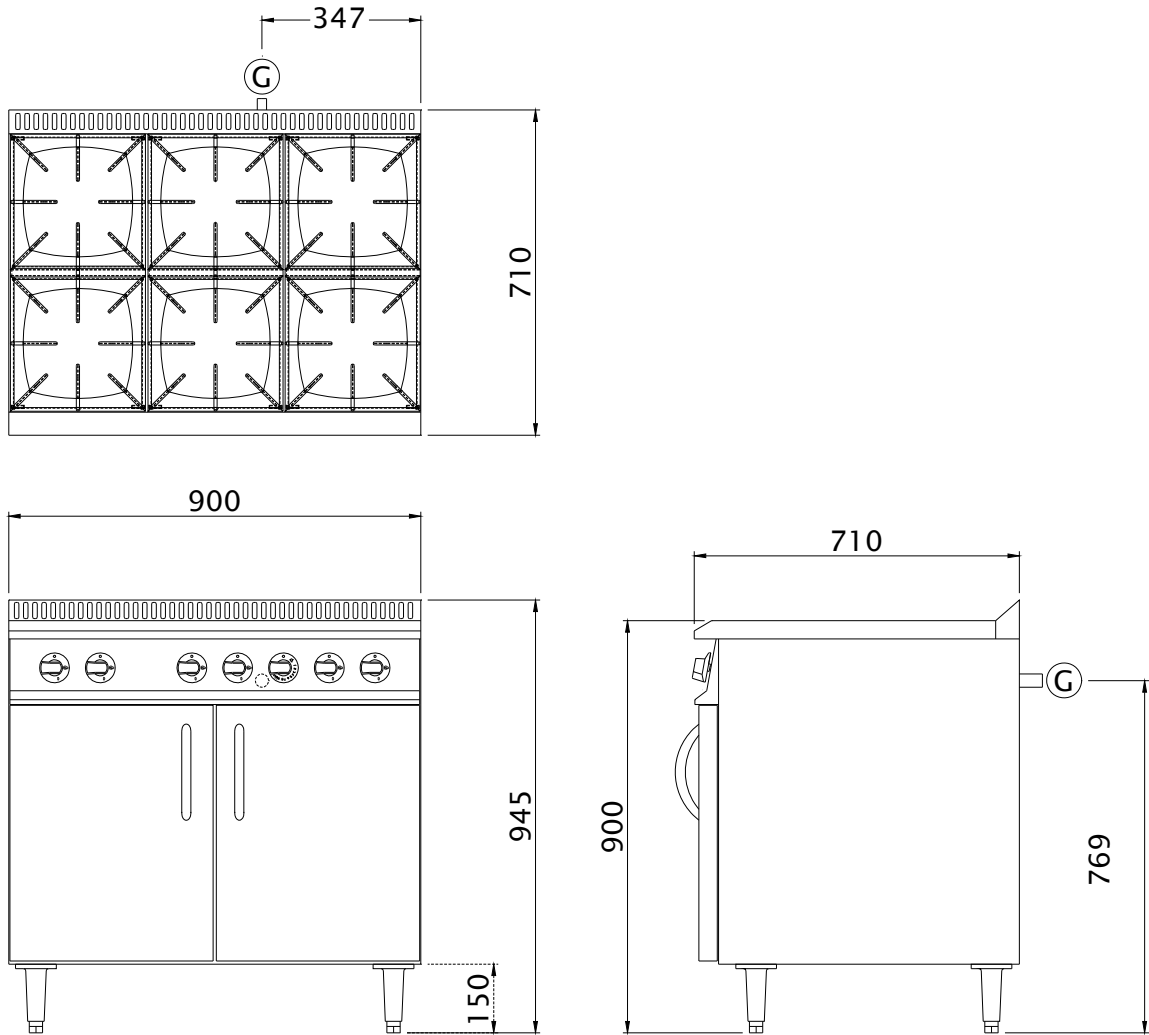

Specification (cont.)

1200mm Open Top Range

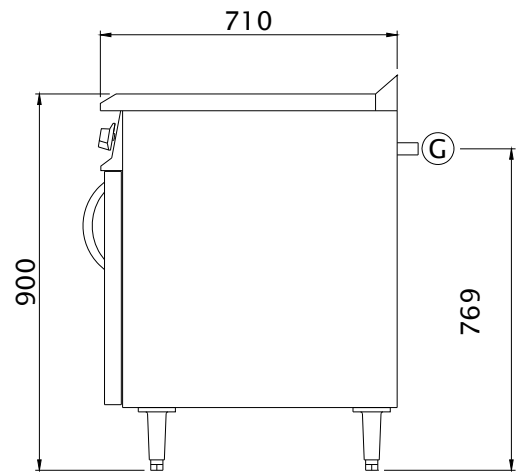
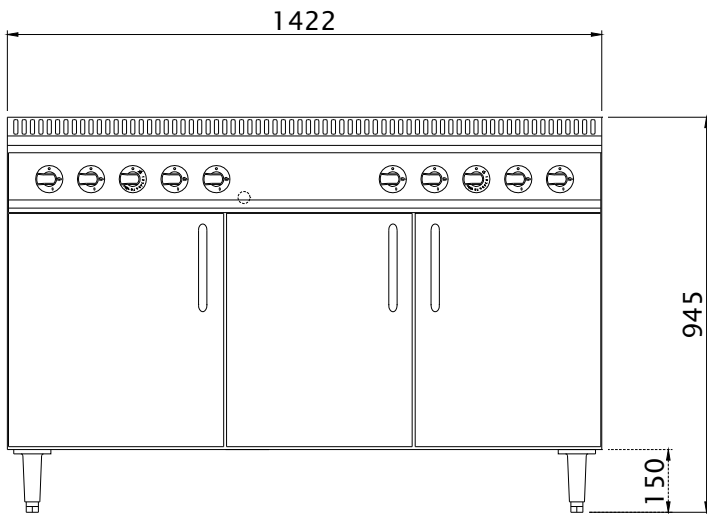
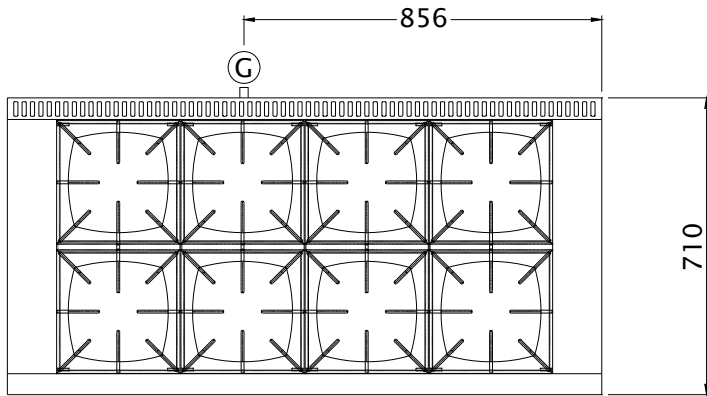

INSTALLATION

Important

Your attention is drawn to the latest GAS SAFETY (INSTALLATION & USE) REGULATIONS 2000.

This appliance **MUST** be installed by a competent person in accordance with these and any other relevant regulations. Users, too, should be aware of the regulations governing the use of gas appliances, particularly with respect to the need for regular servicing.

Before Installation

Before commencing installation, remove all packaging materials from the appliance. It is suggested that any protective film adhering to the stainless steel panels should be left on until installation is completed. **BUT THIS MUST BE REMOVED BEFORE COMMISSIONING OR OPERATING THE APPLIANCE.**

Check the appliance Data Plate (located on the rear of the flue upstand/splashback panel), to ensure that the appliance is suitable for the gas supply available.

Ensure that the floor upon which the appliance is to stand is level and capable of adequately supporting the weight of the appliance. Legs in place of castors are recommended where the floor is found to be uneven.

THE FLOOR MUST BE FIRE-PROOF. If it is not, or if any adjacent wall or surface is made of a combustible material, then the installer **MUST** ensure that the requirements of the **LOCAL FIRE REGULATIONS** are observed.

Positioning

Place the appliance in position allowing a minimum gap of 150mm (6") at the rear and at least 150mm (6")* between the sides of the appliance and any adjacent wall. If the appliance is being suited then please refer to the separate instructions. The minimum distance between the hotplate and any overshelf or ceiling constructed of a combustible material must be 1525mm (60").

For Elevated appliances the minimum distance between the top of the unit and any overshelf or ceiling constructed of a combustible material must be 600mm (24"), or 450mm (17.7") for non combustible material.

Adequate ventilation is essential for safe operation of a gas appliance. A supply of fresh air is necessary for the correct combustion of the gas and there must be a means of exhausting the heat and the products of combustion from the kitchen. It is recommended that the appliance be sited below a ventilating hood, one preferably connected to an extractor system incorporating a grease filter.

These appliances are to be installed with sufficient ventilation to prevent the occurrence of unacceptable concentrations of substances harmful to health in the room in which they are installed

Installation (cont.)

Important Note

The appliance MUST NOT be connected DIRECTLY to a flue or ventilating system, although the flue products of two or more appliances may be directed into a common outlet when building a suite of appliances (see separate instructions for suiting appliances).

Legs in place of castors are recommended where the floor is found to be uneven, ensure that the appliance is level in two places – front to rear and side to side. To check the level it is recommended that a spirit level be placed on a shelf in the open oven – NOT on top of the hotplate! Level can be achieved by adjusting any or all of the screw in feet in each corner of the base. Turn anti-clockwise to lower and clockwise to raise the corner.

Gas Connection

Natural Gas: The size of the supply pipe should be no smaller than ½” BSP and an easily accessible stopcock must be fitted in the gas line adjacent to the appliance. The gas governor provided with the appliance MUST be fitted in the supply line BETWEEN the stopcock and the appliance.

Although a rigid gas pipe is recommended, armoured flexible pipe of a GAS COUNCIL APPROVED PATTERN may be used.

NOTE:

Due to the pressure loss through the snap connection fitting on flexi hoses you must fit a 1 “ flexible hose to the following models:

MV2RGP120-0T-NG

Ensure that all the pipes to the appliance are clean and free from swarf etc, BEFORE making the final connection.

Propane Gas: Follow the same procedure as that for Natural Gas EXCEPT that the Gas Governor MUST NOT be fitted – the Gas Supply Tank or Cylinders are already fitted with a Gas Regulator.

Leak Test

Clean off any protective film from the stainless steel panels.

AT THIS STAGE, LEAK TEST THE WHOLE SYSTEM. THE GAS SAFETY REGULATIONS require that ALL connections in the gas supply line between the Gas Meter and the appliance is tested for gas leaks.

THIS MUST BE DONE BEFORE COMMENCING TO COMMISSION THE APPLIANCE.

Installation (cont.)

Checking and Commissioning (cont.)

ALTHOUGH EVERY APPLIANCE IS TESTED AND SET BEFORE IT LEAVES THE FACTORY, IT IS IMPORTANT THAT THE INSTALLER RE-CHECKS CERTAIN FUNCTIONS BEFORE LEAVING THE SITE.

CHECK THE GAS PRESSURE AT THE APPLIANCE THUS: –

The pressure test point is located on the manifold rail behind the front control panel, which is secured by screws.

Connect a manometer (U tube) to the test point. For the 600 and 900 ranges light the oven and 3 top burners. For the 120 Range light both the ovens and 4 top burners. Check that the pressure reading agrees with that stated on the data Plate.

SHOULD ADJUSTMENT BE NECESSARY, PROCEED AS FOLLOWS: –

FOR PROPANE GAS, REFER TO SUPPLIER.

On the gas governor:–

Remove the cap in order to gain access to the pressure adjusting screw.

Turn the pressure adjusting screw clockwise to increase the pressure or anti-clockwise to decrease it.

When the pressure reading is correct, refit the cap to the governor.

Turn the gas supply to the unit OFF at the stopcock and disconnect the manometer (U tube). Ensure that the pressure test point screw is refitted.

Turn the gas supply to the appliance on at the stopcock and leak test the pressure test point.

Burner Aeration

The aeration of all the burners is fixed and does not need adjusting. . Do not disturb the air combustion admission or the combustion products evacuation on open top burners.

USERS INSTRUCTIONS

Important Note!

The attention of the user is drawn to the requirements of the GAS SAFETY (INSTALLATION & USE) REGULATIONS 2000. This appliance **MUST** be used in accordance with those, particularly so in respect of the need for regular servicing.

The attention of the user is also drawn to the requirement that those parts that have been protected by the manufacturer or his agent are not to be adjusted by the user.

See also the sections of this manual referring to Cleaning and General Maintenance.

Safety Note:

This appliance is intended for professional use and shall only be used by qualified personnel.

Take care when opening the oven door while the cooking chamber is still hot. note other Parts and surfaces of this appliance also become hot during use. It is the responsibility of the kitchen supervisor to inform and warn every user and kitchen worker of this and, furthermore, to ensure those users wear and use protective clothing when operating the appliance.

Should any adjustment or attention be necessary, you are advised to contact your nearest CORGI (Confederation for the Registration of Gas Installers) Service Engineer immediately. The need for regular servicing is detailed in the GAS SAFETY (INSTALLATION & USE) REGULATIONS 2000.

IF YOU THINK THAT GAS IS ESCAPING, ACT IMMEDIATELY. SHUT OFF THE GAS SUPPLY AT THE METER OR EMERGENCY CONTROL, CONTACT THE SUPPLIER OF YOUR GAS IMMEDIATELY.

MAKE SURE THAT ALL USERS OF THIS APPLIANCE KNOW WHERE THE GAS SUPPLY STOPCOCK IS LOCATED FOR THE USE IN AN EMERGENCY.

Improvements

The policy of **Viscount Catering Ltd** is such that each product is subject to continual improvement. The company reserves the right to alter the design of any appliance without prior notification and without the responsibility to update any delivered or in-service appliance and, furthermore, without incurring the responsibility for altering these instructions. In such circumstances, it may be found that the appliance detailed herein differs in certain respect from the one supplied.

For further details or enquires please contact:

Enodis UK Food Service Group

Enodis House, 5E Langley Business Centre, Station Road, Langley, Berkshire, SL3 8DS

Tel: +44 (0) 1753 485900

Fax: +44 (0) 1753 485901

Users Instructions (cont.)

Pan size

The maximum pan size to be used is 34cm and the minimum pan size to be used is 12cm to ensure satisfactory combustion and stability

Lighting Instructions:

Open Hotplates

- 1) To turn on an individual open top hotplate burner, push in the appropriate gas tap knob and turn it anti-clockwise to the double flame position, the "Full ON" position. At the same time apply a lighted taper to light the burner head.
- 2) Keep knob depressed for a further 20 seconds until flame is established.
- 3) If flame is extinguished on releasing knob, wait 3 minutes then repeat steps 1 & 2.
- 4) To turn down or lower the heat, turn the gas tap knob anti-clockwise from the "Full On" position until the desired flame height is reached. Turned fully anti-clockwise to the single flame position, is the lowest setting.

Note! When first lighting the appliance or after installation or after an extended shut-down period, it may be necessary for gas control knob to remain pushed in for some time before burner will light, owing to the presence of air in gas line.

To Turn Off:

Turn the gas tap knob fully clockwise (beyond the "Full On" position) to the "Off" position.

Drip Tray:

A drip tray is fitted beneath the burners to catch any spillage. During normal use this drip tray and handle get hot. Only remove the tray after it has cooled or with suitable gloves.

Oven

Lighting Instructions:

Open the oven doors. The oven burner is visible with the spark electrode and thermocouple secured to it.

- 1) Open the oven door.
- 2) Turn the thermostat knob (B) anti-clockwise to the ignition position Ξ and at the same time press the spark ignition button on the front of the oven base to generate a spark.

Users Instructions (cont.)

- 3) Keep the thermostat knob depressed for a further 20 seconds until the flame is established.
- 4) If the flame is extinguished on releasing knob, wait 3 minutes then repeat steps 2 & 3.
- 5) When the flame is established, turn the thermostat knob to the required setting and note the burner comes FULL ON. Close the oven door securely.

Users Instructions (cont.)

Lighting Instructions: (cont.)

When setting the thermostat knob to the required temperature, turn the knob to Mark 9 (maximum) AND THEN back to the required setting.

Note! When first lighting the appliance or after installation or after an extended shut-down period, it may be necessary for gas control knob to remain pushed in for some time before burner will light, owing to the presence of air in gas line.

To Turn Off:

Turn the thermostat knob clockwise to the “OFF” position.

Using the Oven:

There are 6 shelf positions provided so that the two shelves can be put at different heights. The hottest part of the oven being at the top, and the coolest at the bottom. The oven temperatures in the following table are those at the centre of the oven. The temperature guide given below is only intended as a guide to the gas mark settings on the appliances thermostat knob. It is provided in order to, assist the user to adapt a temperature or a cooking time given in a recipe. The actual temperature at the centre of the oven has been determined by the manufacturer and it will not necessarily correspond to the guides given elsewhere. Using this guide should produce the desired result but it is strongly recommended that the user make note of the best results for future reference.

Mark	1	2	3	4	5	6	7	8	9
°C	144	158	172	186	200	215	230	245	260
°F	291	316	342	367	392	419	446	473	500

The temperatures will vary from the above figures by as much as 20°C hotter at the top of the oven and 30°C cooler towards the bottom of the oven. But remember these are temperatures in an empty oven.

To cook identical products on two shelves, select two shelf positions with a sufficient gap between them to allow air movement in the oven. For example, cooking small cakes or pastry use shelf positions 2 & 5, counting from the top of the oven. Allow the food to cook for just over half the normal time and then change the position of the shelves.

As an alternative leave the food on the upper shelf until it is cooked, then move the food from the lower shelf to the upper shelf, or leave on the lower shelf until cooked.

Users Instructions (cont.)

Cooking identical foods on three different shelves is seldom satisfactory and is not recommended, but the “cool zone” at the oven bottom can be sometimes used for slow casseroles, whilst general and specialised cooking is carried out on the two shelves.

The following cooking chart is for guidance on thermostat settings. Make a note of the settings you find most acceptable.

Usage and Method	Products	Thermostat Setting
High Temperature Roasting	Meat or Poultry	6 or 7
Low Temperature Roasting	Meat or Poultry	3
High Temperature Baking	Bread or Scones	8
Medium Temperature Baking	Queen Cake sponge	5
Low Temperature Baking	Slab Cake	2
Pastry	Puff Pastry	8
	Flaky Pastry	7
	Hot Water Pastry (Pork Pies etc)	4
	Shortcrust Pastry	6
	Plate Tarts	6
Puddings	Milk Pudding	3
	Baked Custard	3

Cleaning the Equipment:

It will be found that it takes less time and effort if appliances are cleaned every day, particularly while they are still warm and before grease or spillage's are burnt on.

PROPRIETARY OVEN CLEANER MUST BE USED WITH CARE. THEY ARE HIGHLY CORROSIVE AND MAY CAUSE DAMAGE TO SURFACES AND COMPONENTS.

Users Instructions (cont.)

Cleaning the Equipment (cont.)

Open Top Hotplates

Wipe the open top pan support grids clean of grease and spillage's regularly – even during cooking sessions – a crust of burned on carbon, coating the pan supports is unsightly, is a health hazard and will impair cooking efficiency.

Daily: Soak the pan support grids in a mild solution of a grease dissolving agent or detergent – DO NOT USE A CAUSTIC CLEANING AGENT – and wash. Accumulated deposits may be removed by soaking and then carefully scraping or a fine cleaning paste could be tried.

SOME PAN SUPPORT GRIDS ARE VITREOUS ENAMELLED – DO NOT USE CAUSTIC CLEANERS AT ALL. WIPE OVER WITH A LIGHT COATING OF COOKING OIL AFTER CLEANING AND DRYING.

The burner caps and burner rings may be removed from the open hotplate burners for cleaning. Soak and wash in a mild detergent solution, rinse and dry thoroughly before replacing. DO NOT allow water or cleaning agents to enter the burner venturi.

DO NOT use caustic cleaners on burner parts. DO NOT scrape or poke the burner port ring, soak and then carefully BRUSH clean any stubborn accumulations of dirt.

REPLACE THE BURNER COMPONENTS CAREFULLY IN THEIR CORRECT POSITIONS.

Brush or scrape all accumulated rubbish from the burner tube covers into the hotplate drip tray. Wipe down with a grease absorbing material.

Remove the full width drip shield by removing the pan supports and burner caps/rings first. The drip shield can be cleaned by washing with a mild detergent solution, rinse and dry before replacing. This is one of those jobs which MUST be carried out on a daily basis and IMMEDIATELY following a spillage.

The Oven

The oven shelves and the oven shelf supports can be removed for cleaning. Withdraw the shelves in the normal way, rub them free of grease using an absorbent paper pad and wash in a hot detergent solution. Rinse and dry before replacing.

The shelf supports are removed by lifting them free from their locating brackets and withdrawing them from the oven interior. They, too, can be washed in a hot detergent solution and rinsed and dried before replacing.

Clean the oven interior and the oven door–lining daily, using a hot mild detergent solution. This is especially necessary if a spillage has occurred, meat has been roasted or fruit pies baked. Rinse with clean water. Stubborn accumulations can be gently scraped off after soaking.

Users Instructions (cont.)

Cleaning the Equipment (cont.)

The Oven

DO NOT USE CAUSTIC OR ABRASIVE CLEANING AGENTS.

Leave the oven drip tray in position while you clean the oven, it will collect all the bits and drips and can be removed for cleaning at the sink.

Clean stainless steel with soap and hot water or a mild detergent solution. Rinse and dry thoroughly.

DO NOT USE CAUSTIC OR ABRASIVE CLEANERS. DO NOT USE ABRASIVE PADS.

Vitreous enamelled surfaces should be wiped clean of grease and Spillage's BEFORE they are burnt on.

Use a mild solution or a grease dissolving agent or a detergent as a soak and wash. Accumulated deposits may be removed by soaking and then carefully scraping or by using a fine cleaning paste.

DO NOT USE CAUSTIC CLEANERS.

On a weekly basis, remove all the oven furniture and the oven bottom panels – the drip tray and the bottom baffles when fitted. CLEAN OUT the bottom compartment – this is the oven burner compartment and it must be emptied of all loose debris and carbon deposits.

DO NOT DISTURB THE OVEN BURNER OR ELECTRODE/SENSOR.

DO NOT USE WATER OR A LIQUID CLEANER ON THE OVEN BURNER.

Brush clean using a dry bristle brush.

General Maintenance and Care.

This equipment is designed and manufactured to give you long, satisfactory service at low cost, provided that it is given proper care and attention at all times. Frequent cleaning and regular checking of correct adjustment will be rewarded by reduced operating and maintenance costs, minimum downtime, and regular results from your cooking.

The flame ports of gas burners must be clean and unobstructed. The user must brush them clean, using a dry bristle brush.

THE UNBLOCKING OF GAS BURNER PORTS IS BEST LEFT TO A QUALIFIED SERVICE ENGINEER

Users Instructions (cont.)

General Maintenance and Care (cont.)

All gas taps and gas controls must operate smoothly and freely without sticking or jerking. A QUALIFIED SERVICE ENGINEER MUST carry out re-lubrication.

WE RECOMMEND THAT ALL EQUIPMENT IS SERVICED AT LEAST ONCE A YEAR, BUT MAY BE AS FREQUENT AS 6 MONTHS OR LESS IF THE GAS TAPS/THERMOSTAT AND GAS CONTROLS DO NOT OPERATE FREELY. ALL WORK MUST BE CARRIED OUT BY A QUALIFIED SERVICE ENGINEER.

SERVICE INTERVALS CAN BE AFFECTED BY SPILLAGE AND SHOULD BE ASSESSED EACH TIME THE EQUIPMENT HAS BEEN USED.

SERVICE AND MAINTENANCE

Maintenance MUST only be carried out by a competent person. Ensure that the gas and electricity supply to the appliance has been turned "OFF" before dismantling any components.

Routine Maintenance Procedure:

- 1) Turn "ON" the oven or both ovens on a 120 range (and three top burners or 4 on a 120 range) and Check that the gas pressure at the test point is as stated on the data plate.

Natural Gas - 15 mbar (6" wg)

Propane Gas - 37 mbar (14" wg)

- 2) Turn on each hotplate burner in both full and turn-down positions.
- 3) Carry out the lighting procedure for the oven and check that the ignition and the burner flames are satisfactory.
- 4) Turn off the gas supply to the range.
- 5) Remove the pan supports and burner caps. Clean out the burner Caps.
- 6) Ensure that the burner injectors and burner air passages are clear. Replace burner caps.
- 7) Re-grease the hotplate gas taps as required and ensure that the barrels are secured by the two niting screws.
- 8) Turn on the gas supply.
- 9) Remove the oven shelves and drip trays.
- 10) Brush off any spillage on the oven burner. Ensure the electrode is clean and that the spark gap is 3-4mm.
- 11) Check the condition of the door seals and doors are not leaking.
- 12) Replace oven furniture.
- 13) Check the operation of the thermostat and re-grease if necessary.
- 14) Light each burner in turn and check full and turn-down rate.
- 15) Replace the pan supports.
- 16) Check the oven lighting procedure.

Service and Maintenance (cont.)

Fault	Possible Cause	Remedy
OPEN TOP BURNER		
Burners will not stay alight.	Faulty connection at thermocouple valve.	Make re-connection
	Thermocouple incorrectly located.	Re-position thermocouple
Burner goes out when turned too "low".	Blockage in tap.	Clean and re-grease.
	By-pass too low	Adjust by-pass screw.
Irregular flame.	Burner ring, cap not located.	Re-locate
	Low pressure.	Check pressure at Test Point.
OVEN		
Failure to ignite	Accumulation of dirt or grease around burner ports	Clean
	Connection broken or disconnected	Replace Lead/reconnect
Burner fails to establish on minimum rate.	Loose thermocouple	Tighten thermocouple
	Electro-magnetic unit failure	Replace gas taps.
	By-pass too low	Adjust by-pass screw.
Oven too hot or cold	Thermostat calibration out	Re-calibrate or replace
Main burner will not stay alight Main burner goes out whilst in use	Loose thermocouple Thermocouple incorrectly located.	Tighten, Reposition thermocouple
	By Pass flame set too low	Increase bypass rate

Service and Maintenance (cont.)

ENSURE THAT THE GAS SUPPLY TO THE APPLIANCE HAS BEEN TURNED OFF BEFORE REMOVING OR DISMANTLING ANY GAS CONTROLS.

1) Removal of Oven Thermostat/FFD.

Remove the shelves and drip tray from the oven together with the hotplate drip tray(s). Pull off all the control knobs from the horizontal control panel, and remove by unscrewing the two fixing screws. Remove rubber thermostat shroud by pulling off thermostat spindle. From inside the oven, unclip the thermostat phial from its holder and ease it through the top panel.
Remove the pan supports together with the burner caps and skirts.
Also lift off the full width drip shield.

ENSURE THAT THE THERMOSTAT PHIAL IS NOT KINKED – HAS NO SHARP BENDS AND IS CORRECTLY LOCATED IN ITS HOLDER.

2) Removal of Oven Thermocouple.

Disconnect the thermocouple–sensing tip from the RH side of the oven burner (taking note of its position) by unscrewing the M8 fixing nut.
Access to the thermocouple connection on the thermostat is obtained by following the procedure for removing the Oven Thermostat (Section 1).
When re–fitting the thermocouple, ensure that the sensing tip is positioned correctly with the tip inside the flame pattern.
Tighten the connection to the thermostat finger tight and then add a further ¼ turn using a spanner, DO NOT OVER–TIGHTEN – this can break the seal and continuity.

Service and Maintenance (cont.)

3) Removal of Oven Burner or Burner Injector.

Remove the shelves and drip tray from inside the oven. This exposes the burner and its supply tube.

The oven burner injector can be removed for cleaning, etc., without disturbing the burner. Disconnect the burner supply tube at the union on the injector elbow (immediately before the burner).

Remove the thermocouple from the burner by unscrewing the M8 nut and easing the thermocouple tip from the basket (taking note of its position).

Remove the ignition electrode by pulling off the electrode lead, and unscrewing the single screw securing the electrode to the burner bracket.

The injector elbow can now be unscrewed from the burner thus exposing the injector.

To clean the injector, brush off with a stiff bristle brush any dirt, blow through the orifice to remove any blockage or restriction – DO NOT POKE WIRE THROUGH THE INJECTOR ORIFICE.

To remove the burner: –

Proceed as described above for removing the injector.

Remove the screws at each side of the burner holding the brackets to the oven base.

The burner, complete with its fixing brackets, can be lifted out.

4) To Remove a Open Top Burner Thermocouple.

Remove the control knobs and control panel, which is secured by two fixing screws.

Remove the pan supports.

Remove, by lifting clear, the burner cap, ring, support (skirt) and full width drip shield.

Disconnect the thermocouple-sensing tip from the burner rail (taking note of its position) by unscrewing the M8 fixing nut. Unscrew the thermocouple from the Gas Tap/FFD and withdraw the thermocouple.

When re-fitting the thermocouple, ensure that the sensing tip is positioned correctly with the tip inside the flame pattern.

Tighten the connection to the thermostat finger tight and then add a further ¼ turn using a spanner, DO NOT OVER-TIGHTEN – this can break the seal and continuity.

Service and Maintenance (cont.)

5) To Remove or clean a Open Top Burner Injector.

Remove the pan supports.

Remove, by lifting clear, the burner cap, ring, support (skirt) and full width drip shield.

The injector can be unscrewed using a suitable socket spanner.

To clean the injector, brush off with a stiff bristle brush any dirt, blow through the orifice to remove any blockage or restriction – DO NOT POKE WIRE THROUGH THE INJECTOR ORIFICE.

6) Servicing and removing a Gas Tap/FFD.

Remove the control knobs and control panel, which is secured by two fixing screws.

Remove the pan supports.

Remove by lifting clear, the burner cap, ring, support (skirt) and full width drip shield.

The front of the gas tap is now exposed and the procedure for cleaning and re-greasing the tap can be carried out.

Remove the gas tap from the gas rail by unscrewing the supply tube union connection and unscrew the single screw in the clamping bracket below the gas tap.

To clean and re-grease a gas tap: -

Remove the front cover from the gas tap by unscrewing the two Pozi head screws.

Carefully withdraw the cover taking care not to lose the small spring from inside the tap.

Carefully pull the taper plug from the body of the gas tap.

Clean the plug and the inside of the body using a lint-free cloth and a suitable solvent.

Wipe both parts clean and dry. Ensure that all the holes are clean and free from obstruction.

Lightly re-grease the plug using suitable high temperature grease, such as Rocol, and replace the plug in the gas tap body.

Lightly grease the inside of the gas tap front cover, position the spring and re-assemble the front cover to the body.

DO NOT WORK ON MORE THAN ONE TAP AT A TIME.

ENSURE THAT THE PLUG IS PLACED IN THE CORRECT BODY.

Service and Maintenance (cont.)

10) To Convert NG Appliances to LP Gas. (Open Top)

Remove the control knobs and control panel, which is secured by two fixing screws.

Remove the pan supports.

Remove the hotplate burner injectors as described in Section 5 and fit replacement 1.2mm LP injectors (932869-02) and re-fit burner caps etc.

Working from the front of the appliance screw in fully both the thermostat and Gas Tap/FFD by-pass screws.

From inside the oven remove the oven injector as described in Section 3 and fit replacement LP injector.

900 Range – 1.32mm (924024-09)

600 Range – 1.18mm (924024-06)

Remove the gas governor from the inlet supply pipe.

Finally fit replacement Data Plate and re-test the appliance.

11) To Convert LP Appliances to NG Gas. (Open Top)

Proceed as described in Section 10, but substituting NG replacement parts.

Hotplate Injector	2.0mm (932869-01)
Oven Injector 900	2.44mm (924024-08)
Oven injector 600	1.99mm (924024-10)
Governor	(931779-01) 3/4 Governor

Fit replacement gas governor to the inlet supply pipe.

Turn the thermostat by-pass screw anti-clockwise and light the oven burner. Ensure that when the burner cuts-down to by-pass rate the flame envelops the thermocouple tip sufficiently to keep the magnet valve open.

If the flame extinguishes turn the by-pass screw anti-clockwise until the flame is established.

Repeat the above procedure for the hotplate by-pass rates.

Finally fit replacement Data Plate and re-test the appliance.

Service and Maintenance (cont.)

SPARE PARTS LIST

Part Number	Description	Quantity
927123-S1	Thermostat/FFD (0.55mm) (Open Top)	1
932329-01	Thermocouple (Oven)	1 or 2
930875-02	Thermostat Knob	1
929344-02	Piezo Ignition Unit	1 or 2
930389-01	Oven Ignition Lead	1 or 2
930734-01	Oven Ignition Electrode	1 or 2
930733-01	Oven Burner (900) & (120)	1
930733-02	Oven Burner (600) & (120)	1
924024-08	Oven Injector NG 2.44mm (900) & (120)	1
924024-09	Oven Injector LP 1.32mm (900) & (120)	1
924024-10	Oven Injector NG 1.99mm (600) & (120)	1
924024-06	Oven Injector LP 1.18mm (600) & (120)	1
931457-S2	Gas Tap/FFD (0.6mm)	8, 6 or 4
932876-01	Thermocouple (Open Top)	8, 6 or 4
930875-01	Control Knob (Open Top)	8,6 or 4
932869-03	Burner Cap assy (Open Top)	8, 6 or 4
932869-04	Burner Base (Open Top)	8, 6 or 4
932869-05	Olive 10mm Dia (Open Top)	8,6 or 4
932869-06	Nut 10mm Dia (Open Top)	8,6 or 4
932869-07	Jet holder (Open Top)	8, 6 or 4
932869-01	Burner Inj. NG 2.0mm (Open Top)	8, 6 or 4
932869-02	Burner Inj. LP 1.2mm (Open Top)	8, 6 or 4
924402-06	Hinge Pin (Adjustable)	4
932308-01	Arch Handle	1 Per Door
932659-01	Door Magnet	1 Per Door
932574-01	LH Top RH Bottom Hinge	1,2 or 3
932574-02	RH Top LH Bottom Hinge	1,2 or 3
921913-09	Door Seal - 362mm (900) & (120)	2
921913-08	Door Seal - 445mm (900) & (120)	2
921913-08	Door Seal - 445mm (600)	3
930829-01	Oven Shelf Support RH	1 or 2
930829-02	Oven Shelf Support LH	1 or 2
924435-01	Oven Shelf.(900) & (120)	2
924435-02	Oven Shelf.(600) & (120)	2
932599-01	Pan Support painted	2, 3 or 4
932599-02	Pan Support Enamel	2, 3 or 4
931779-01	Gas Governor 3/4 Inch (NG only) (600),(900)&(120)	1
932853-01	Leg 65mm Dia	4

SPARE PARTS LIST (Cont.)

Part Number	Description	Quantity
932811-01	Castor swivel braked	2
932811-02	Castor swivel Un-braked	2
930735-S1	Burner Assy (900)	Spares Kit
930735-S2	Burner Assy (600)	Spares Kit
932948-S1	Conversion Kit NG to LPG 90R (Open Top)	Spares Kit
932948-S2	Conversion Kit LPG to NG 90R (Open Top)	Spares Kit
932948-S3	Conversion Kit NG to LPG 60R (Open Top)	Spares Kit
932948-S4	Conversion Kit LPG to NG 60R (Open Top)	Spares Kit
932948-S5	Conversion Kit NG to LPG 120R (Open Top)	Spares Kit
932948-S6	Conversion Kit LPG to NG 120R (Open Top)	Spares Kit

Spare Parts available from:

Enodis UK Food Service Group
Enodis House
5E Langley Business Centre
Station Road
Langley
Berkshire
SL3 8DS

Tel: +44 (0) 1753 485906
Fax: +44 (0) 845 301 1463

WARRANTY COVER

The Company offer twelve months warranty with each new piece of equipment subject to our normal conditions of sale and will undertake responsibility for warranty subject to the additional following conditions.

Notice of the defect/damage is given within 48 hours of breakdown or in the case of damage four days from the date of despatch and the manufacturer given adequate opportunity to examine the goods in order that appropriate action can be taken.

The Company will not be obliged to repair or replace any goods if after examination the defect/damage is found to be through accident, misuse, neglect, incorrect installation or maintenance by other than approved engineers, or any other cause beyond the reasonable control of the manufacturer.

EXCLUSIONS TO WARRANTY

Normal routine maintenance is not covered and the warranty specifically excludes any problems, which are related to scale caused by hard water and the cleaning of pilot jets. Also excluded from the warranty are the following consumable items.

Tap washers and springs, gaskets, oven lamps and indicating lights, door seals and any other perishable parts.

This warranty in no way prejudices your rights under common law and is offered as an addition to your statutory rights.

CHECK LIST FOR 600/900 MEDIUM DUTY RANGES

Description	Part Number		Checked by
DATA PLATE		*	
		*	
CONTROL KNOBS	Top Burners 930875-01	*	
	Thermostat 930875-02	*	
SHELVES	600 Ranges 924435-02 x 2	*	
	900 Ranges 924435-01 x 2	*	
PAN SUPPORTS	Matt 932599-02	*	
LIGHTING INSTRUCTIONS	927144-01	*	
		*	
GAS GOVERNOR 3/4"	931779-01 Nat Gas Only	*	
EARTH BONDING KIT	Earth Bonding Tab 923206-01	*	
	Earth Bonding Label 923153	*	
MANUAL	932871-01	*	

This unit was packed with pride by -----